



SUBCATERGORIES



SUBCATERGORIES

UNDER
CAR



CAR
UNDER

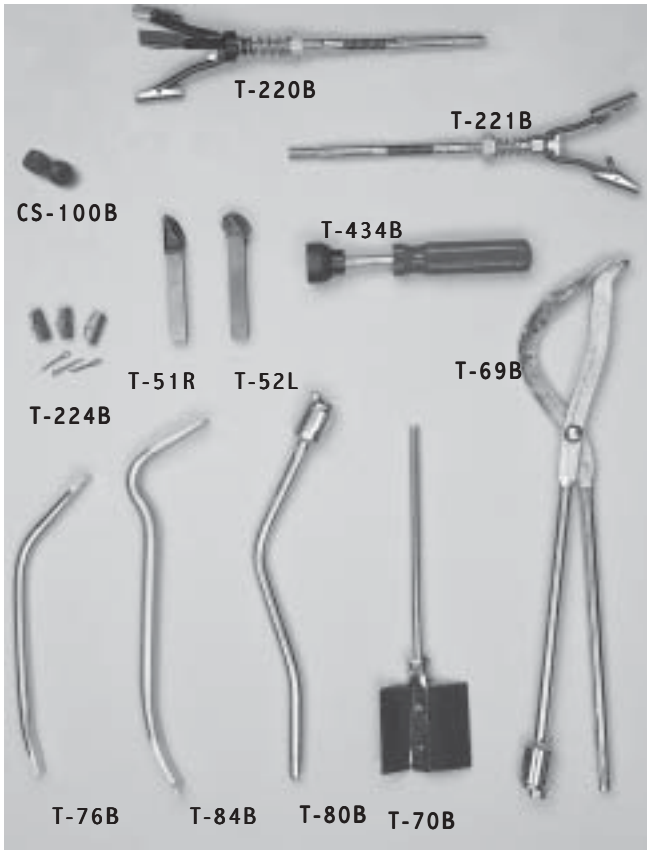

For Master Cylinder Gaskets & Caps see pages 116-117 in Under Hood Section

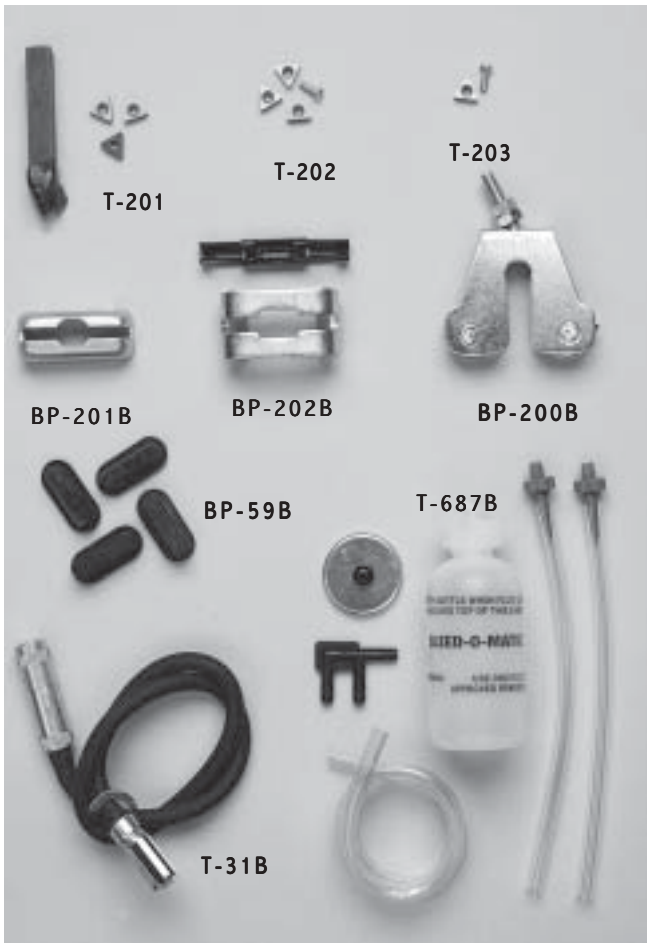

Brake Service Parts

BRAKE ADJUSTING HOLE COVERS

BP-59B Flexible, rectangular plug keeps brakes dry and dirt free on most vehicles. 4/cd.

BRAKE ADJUSTING SPOONS

9" long with special angled and curved ends.

T-76B Universal. For most systems.

T-84B Curved End for Bendix type systems.

BRAKE BLEEDER SCREW CAPS

CS-100B Snap-on style. Protects bleeder screws from corrosion.

BRAKE BLEEDERS — ONE MAN

T-31B Hose with check valve fitting and locking claw fitting for bleeder screw.

T-687B A brake bleeder for wheel cylinders, calipers, & master cylinders while units are on the vehicle. For hydraulic brakes.

BRAKE CABLE CONNECTORS

BP-201B Brake Cable Connector - Fits Fairmont, Ford Full Size, Granada, Maverick, T-Bird 1979-up

BP-202B Brake Cable Connector Assortment - Fits most GM models. Includes "C" type and cylindrical connectors.

BRAKE CABLE SHORTENER

BP-200B Zinc plated steel body and hook with 2 locking nuts. For use on all cars and trucks to prolong cable life for safety.

BRAKE CYLINDER HONE

T-70B Flat spring steel with fine grit paper for 3/4" to 1-3/4" cyl. bore. Hand/ electric drill.

T-220B Adjustable pressure, replaceable pads & flexible shaft for off center honing. 3/4" to 2-1/2" cyl. bore. Use with electric drill.

T-221B Same as T-220B but 5/8" to 1-1/4" bore.

T-224B Set of 3 replacement pads & cotter pins for T-220B, T-221B

BRAKE DRUM CUTTERS & CUTTING TOOL

T-201 Tip holder with locking screw and tip, 6 factory ground cutting edges. Incl. 3 tips.

T-202 Replacement carbide tips for T-201.

T-203 Carbide tool bit for drum and disc brake rotor blades. 6 cutting edges to each bit.

Carbide tipped cutters, 3/8" x 3" for most drum lathes.

T-51R Right hand **T-52L** Left hand

BRAKE SPRING INSTALLER & COMPRESSOR

T-80B Install and remove return springs on Bendix brake systems. End socket fits over most anchor posts.

T-434B Compressor for all brake shoe holddown cups & washers. Domestic & import cars.

BRAKE SPRING PLIERS

T-69B Removes or installs return springs on most drum brake systems. Chrome finish.



Brake Service Parts Cont'd

CALIPER BOLT KEYS & SOCKETS

- T-393B KEY** 3/8" hardened steel. GM Vehicles
- T-455B KEY** 5/16" hardened steel. GM X, J
- T-456B KEY** 1/4" hardened steel. Ford
- T-394B SOCKET** 3/8" drive 3/8" GM Vehicles
- T-408B SOCKET** 5/16" drive 3/8" GM X, J
- T-457B SOCKET** 1/4" drive 3/8" Ford

CALIPER BOLTS

For a quick and easy repair of stripped caliper bolt holes on steering knuckles. Eliminates time spent drilling, tapping or rethreading mounting holes or the expense of replacing steering knuckles. Includes detailed instructions.

- BCB-1B** GM RWD front brakes. Replaces 4-1/8" long bolts. Chevrolet Astro 1983-85, G-10 Van 1971-74, GM vehicles 1969-93, GMC Truck 1971-77, Safari 1985-89.
- BCB-2B** GM RWD front & rear brakes. Replaces 4-1/8" long bolts. Chevrolet/GMC Truck 1971-93, GM vehicles 1968-93, Jeep 1974-93.
- BCB-3B** GM FWD front brakes. Replaces 3-1/8" long bolts. Buick Century, Electra, LeSabre, Skylark 1980-90, Cadillac Deville, Fleetwood 1985-93, Chevrolet Celebrity, Citation, Lumina APV 1990, Oldsmobile 98, Ciera, Delta 88, Omega, Silhouette APV 1980-91, Pontiac 6000, Bonneville, Fiero, Phoenix, Trans Sport APV 1982-90.
- BCB-4B** GM FWD front brakes. Replaces 2-13/16" long bolts. Buick Regal, Skyhawk, Skylark, Somerset 1982-93, Cadillac Cimarron 1982-88, Chevrolet Beretta, Cavalier, Corsica 1982-93, Oldsmobile Achieva, Calais, Ciera, Firenza 1982-93, Pontiac Grand Am, J2000, Sunbird, Trans Sport APV 1982-93.
- BCB-5B** Ford, Motor Co. FWD & RWD front brakes. Continental 1988-92, Cougar, T-Bird, XR-7 1989-93, Escort, EXP, Lynx, LN7 1981-90, Merkur XR4Ti 1985-89, Scorpio 1988-90, Taurus, Sable 1986-93, Tempo, Topaz 1984-92.
- BCB-6B** GM front brakes. Replaces 3-5/8" long bolts. CK1, 2, 3 Pick-Up 2 & 4WD 1/2, 3/4 & 1 ton 1988-94.

BLEEDER SCREWS

- CS-3201B** 10mm x 1.5 x 27
- CS-3202B** 3/8" x 24 x 1.360"
- CS-3203B** 3/8" x 24 x 1.110"
- CS-3204B** 8mm x 1.25 x 24
- CS-3205B** 15/16" x 24 x 1.060"
- CS-3206B** 1/4" x 28 x 15/16"
- CS-3207B** 7/16" x 20 x 1-17/64
- CS-13210B** 10mm x 1.0 x 38
- CS-13211B** 7mm x 1.0 x 35
- CS-13212B** 10mm x 1.0 x 31

BLEEDER SCREW REPAIR INSERT

- CK-1B** Heavy duty brass body (1/8" NPT) with bleeder screw. Replaces broken or corroded bleeder screws on calipers and large wheel cylinders.

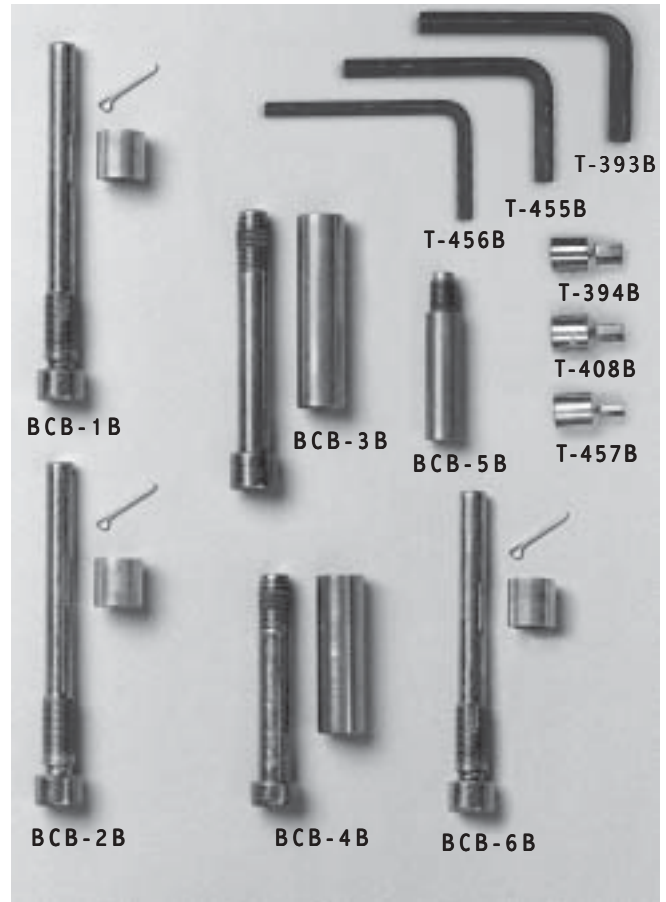

UNDER CAR



CAR
UNDER

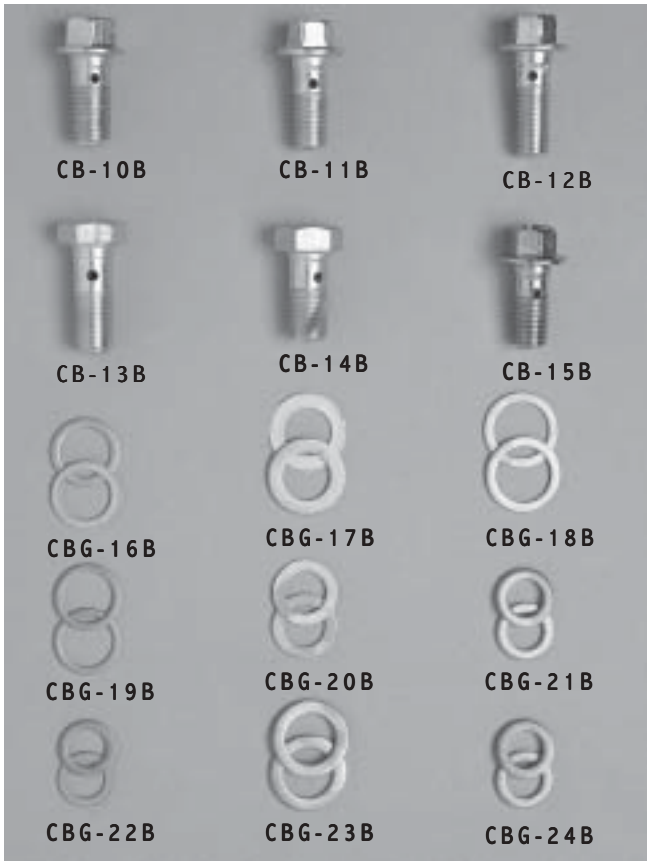

For Power Brake Check Valves see page 122 in Under Hood Section



Brake Service Parts Cont'd

Brake Line Unions see page 91

CALIPER	BOLT	GASKETS		
		I.D.	x O.D.	x Thickness
CBG-16B	33/64"	45/64"		1/32"
CBG-17B	1/2"	13/16"		1/32"
CBG-18B	19/32"	13/16"		1/32"
CBG-19B	17/32"	11/16"		1/32"
CBG-20B	7/16"	11/16"		1/32"
CBG-21B	10/3mm	16.9mm		1.3mm
CBG-22B	25/64"	37/64"		1/32"
CBG-23B	17/32"	13/16"		1/16"
CBG-24B	25/64"	5/8"		1/16"

Caliper Bolt Gaskets available 2/card.

CALIPER HOSE BOLTS

CB-10B	GM FWD	7/16" x 20
CB-11B	Ford RWD	M10-1.50 x 24
CB-12B	Ford FWD	M10-1.50 x 19
CB-13B	CC	RWD
CB-14B	CC	FWD
CB-15B	GM	RWD 1979-87

MASTER CYLINDER BLEEDER KIT

T-1201B Standard. Six thread sizes. For bench bleeding master cylinder on most domestic and light trucks. Use when rebuilding or replacing the master cylinder. Durable plastic for multiple reuse. (Shown on Page 62)

SPLIT BACKING PLATE

SBP-100B GM. Left & right side 1978-92 with 9-1/2" brakes. Installs without removing rear axle shaft.



BRASS FITTINGS

Brass Fittings

- BF-2B** 3/16" compression sleeve
- BF-3B** 1/4" compression sleeve
- BF-4B** 5/16" compression sleeve
- BF-5B** 3/8" compression sleeve
- BF-6B** 1/8" compression sleeve -
Permits compression fittings to be reused.
Replacement part for BF-21B and BF-31B.
- BF-10B** 1/8" compression nut -
Replacement part for BF-21B
- BF-11B** 3/16" compression nut
- BF-12B** 1/4" compression nut
- BF-13B** 5/16" compression nut
- BF-14B** 3/8" compression nut
- BF-21B** 1/8" compression union -
Used for connecting like-sized tubing sections
- BF-22B** 3/16" compression union
- BF-23B** 1/4" compression union
- BF-24B** 5/16" compression union
- BF-25B** 3/8" compression union
- BF-31B** Male connector with 1/8" OD
to 1/8" male NPT - Three piece fitting for
connecting tubing to male pipe thread.
- BF-32B** Male connector with 3/16" compression to
1/8" male NPT.
- BF-33B** Male connector with 1/4" compression to
1/8" male NPT.
- BF-36B** Male connector with 5/16" compression to
1/4" male NPT.
- BF-38B** Male connector with 3/8" compression to
1/4" male NPT.
- BF-70B** Square head brass pipe plug with 1/8" NPT
- BF-71B** Square head brass pipe plug with 1/4" NPT
- BF-72B** Square head brass pipe plug with 3/8" NPT
- BF-74B** Hex head brass plug with 1/8" NPT
- BF-75B** Hex head brass plug with 1/4" NPT
- BF-76B** Hex head pipe plug with 3/8" NPT
- BF-77B** Hex head pipe plug with 1/2" NPT
- BF-81B** Reducing adapter with 1/4" female NPT to
1/8" male NPT.
- BF-83B** Reducing adapter with 3/8" female NPT to
1/4" male NPT.
- BF-90B** Pipe bushing with 1/8" female NPT to 1/4"
male NPT.
- BF-93B** Pipe bushing 1/4" female NPT to 3/8"
male NPT.
- BF-94B** Pipe bushing 1/4" female NPT to 1/2"
male NPT.
- BF-95B** Pipe bushing 3/8" female NPT to 1/2"
male NPT.

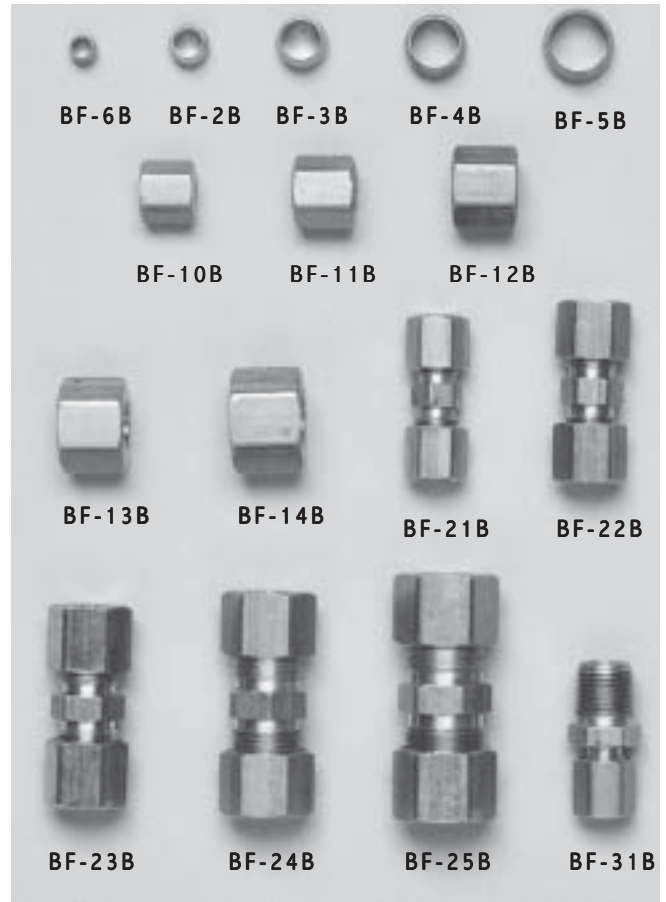

UNDER



CAR



CAR



UNDER

Brass Fittings Cont'd

- BF-120B** Pipe coupling with 1/8" female NPT
- BF-121B** Pipe coupling with 1/4" female NPT
- BF-122B** Pipe coupling with 3/8" female NPT
- BF-124B** Hex pipe nipple 1/8"
- BF-125B** Hex pipe nipple 1/4"
- BF-127B** Hex pipe nipple 3/8"
- BF-130B** 1/8" male NPT close nipple
- BF-131B** 1/4" male NPT close nipple
- BF-132B** 3/8" male NPT close nipple
- BF-141B** 1/4" male NPT x 1-1/2" long nipple
- BF-191B** Reducing adapter, 1/4" female NPT to 3/8" female NPT reducer
- BF-300B** Adapter -
3/16" OD female to 1/4" OD male tube
- BF-301B** Adapter -
3/16" OD female to 5/16" OD male tube
- BF-302B** Adapter -
1/4" OD female to 5/16" OD male tube
- BF-303B** Adapter -
1/4" OD female to 3/16" OD male tube
- BF-311B** Connector - 3/16" OD to 1/8" male NPT
- BF-312B** Connector - 1/4" OD to 1/8" male NPT
- BF-313B** Connector - 1/4" OD to 1/4" male NPT
- BF-314B** Connector - 5/16" OD to 1/8" male NPT
- BF-315B** Connector - 5/16" OD to 1/4" male NPT
- BF-316B** Connector - 3/8" OD to 1/8" male NPT
- BF-317B** Connector - 3/8" OD to 1/4" male NPT
- BF-644B** Fuel hose fitting -
1/4" ID hose to 1/4" inverted flare
- BF-655B** Fuel hose fitting -
5/16" ID hose to 5/16" inverted flare
- BF-656B** Fuel hose fitting -
5/16" ID hose to 3/8" inverted flare
- BF-666B** Fuel hose fitting -
3/8" ID hose to 3/8" inverted flare
- BF-742B** Fuel hose fitting -
1/4" ID hose to 1/8" male NPT
- BF-744B** Fuel hose fitting -
1/4" ID hose to 1/4" male NPT
- BF-752B** Fuel hose fitting -
5/16" ID hose to 1/8" male NPT
- BF-754B** Fuel hose fitting -
5/16" ID hose to 1/4" male NPT
- BF-762B** Fuel hose fitting -
3/8" ID hose to 1/8" male NPT
- BF-764B** Fuel hose fitting -
3/8" ID hose to 1/4" male NPT
- BF-765B** Fuel hose fitting -
3/8" ID hose to 1/4" male NPT. Elbow
- BF-766B** Fuel hose fitting -
3/8" ID hose to 3/8" male NPT



Car & Truck Anti-Static Strap

Eliminate static electric shocks on cars and trucks.

AS-5B 18" thick rubber strap with attached mounting bracket and screws. 1/card.

AS-10C Display card contains 10 AS-5.

Clutch Pilot Bushings/Bearings

	Inside dia.	Outside dia.	Length
PB-5B	.753	.940	.880
	CC (53298)		
	Chrysler Corp. 1928-89		
PB-14B	.593	1.094	.750
	AMC (412562, 3168006, 8132261), GM (142655, 3752487, 10040408)		
	American Motors 1964-87		
	G M 1938-92		
PB-18B	.672	1.576	.500
	FO (B-7600A, 70-7600A, 70-7600B)		
	Ford Motor Co. 1928-71		
PB-19B	.629	1.066	.447
	AMC (639578)		
	American Motors 1940-72		
PB-21B	.629	.816	.693
	AMC (3106507, 3168006), Nissan (32202-B3000, 32202-B5900)		
	Nash, Hudson, Kaiser 1946-62		
PB-23B	.593	1.381	.437
	GM (907109, 907321)		
	G M 1937-91		
PB-24B	.593	1.060	.750
	Special Adapter		
PB-28B	.630	1.380	.505
	FO (C0DD-7600A, CODZ-7600A)		
	Ford Motor Co. 1953-70		
PB-39B	.673	1.380	.563
	FO (C8AZ-7600A, D2DZ-A, D4DZ-A, D8TZ-A, E3TZ-A)		
	Ford 1968-88		
PB-44B	.596	.829	.562
	FO (D1FZ-7600B, D4ZZ-A)		
	Ford 1971-88		
PB-45B	.472	1.102	.315
	Toyota (97123-06001)		
	Toyota 1970-89		
PB-46B	.472	1.260	.394
	Toyota (97143-06201)		
	Toyota 1969-86		
PB-47B	.591	1.260	.354
	CC (MD002613)		
	Chrysler 1970-88		
	Honda 1972-89		
PB-48B	.669	1.575	.472
	GM (900529, 94022582)		
	G M 1982-85		
PB-50B	.591	.825	.587
	FO (D4ZZ-7600A,E3TZ-C,E5TZ-A)		
	Ford 1979-91		
PB-56B	.592	.828	.743
	GM (476574)		
	G M 1982-91		
PB-25A	Assortment contains: 6 ea. PB-5, PB-14, 4/PB-18, 2/PB-19, 3/PB-21, 2/PB-23, 2/PB-28.		

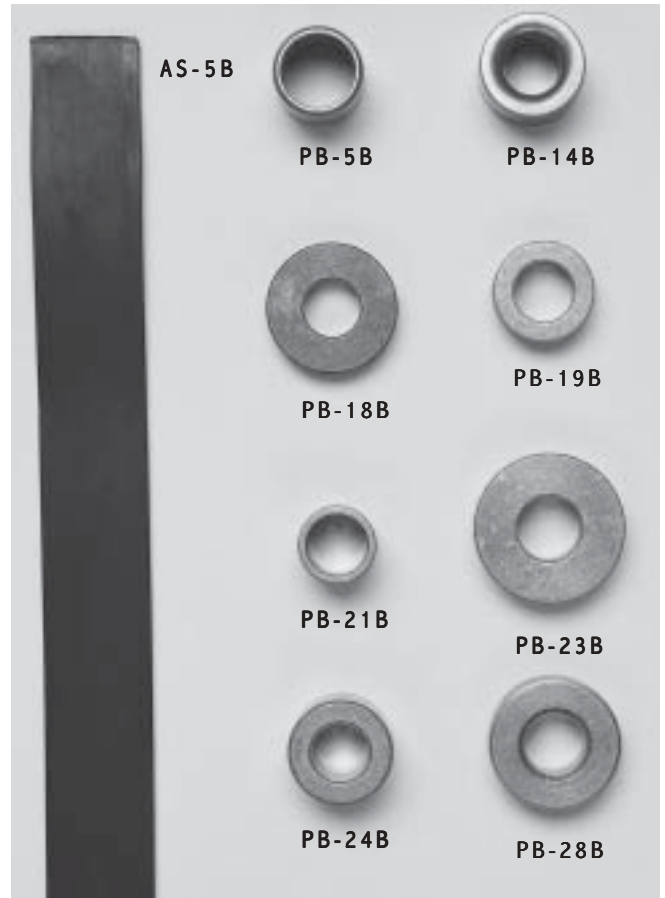

For Clutch Alignment tools see pages 65-66 in Tools Section

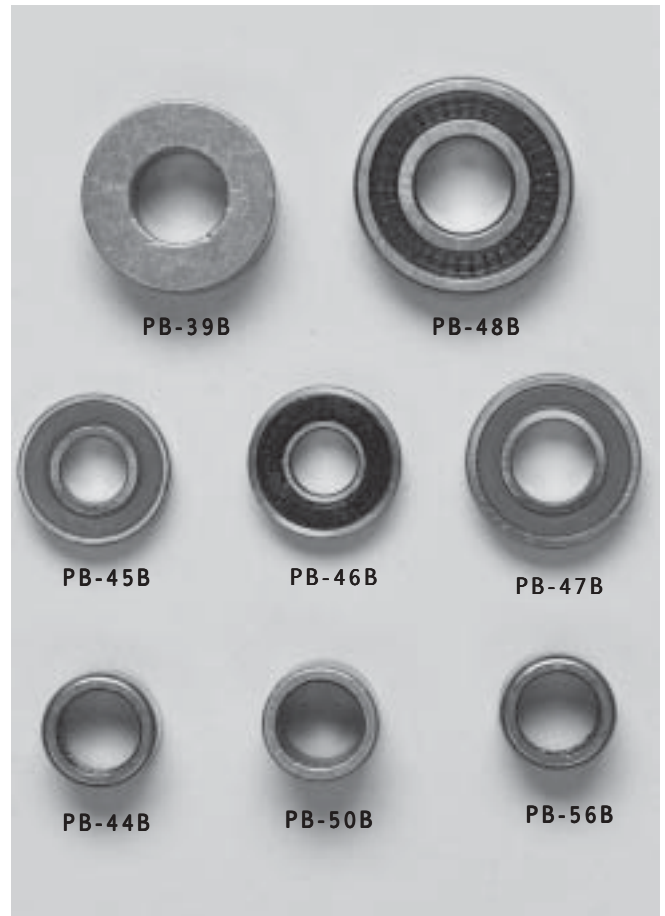

UNDER CAR



CAR
UNDER

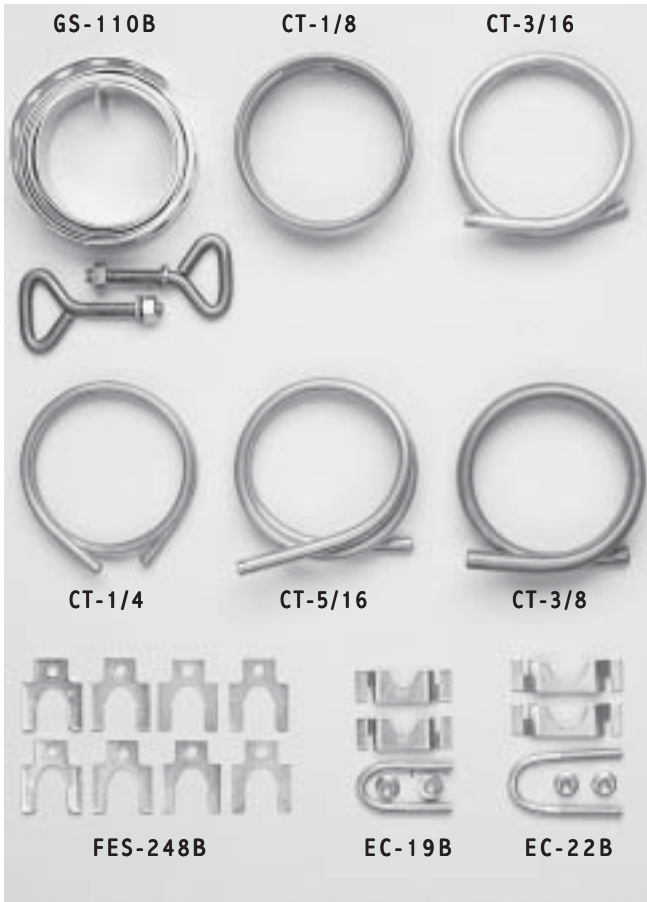

Copper Tubing — Seamless

	O.D.	Wall	Gauge	Coil	Length
CT-1/4	1/4"	.030		25'	
CT-1/4-20B	1/4"	.030		20"	
CT-1/8	1/8"	.030		25'	
CT-1/8-72B	1/8"	.030		72"	
CT-3/16	3/16"	.030		25'	
CT3/16-24B	3/16"			24"	
CT-3/8	3/8"	.032		25'	
CT-3/8-24B	3/8"	.032		24"	
CT-5/16	5/16"	.032		25'	
CT5/16-24B	5/16"			24"	

Emission Clamps

Contains U-bolt, interlocking clamp and hex nuts.

EC-19B GM 3.8, 4.4, 5.0L Engines

EC-22B Connects A.I.R. Pipe to catalytic converter. Ford Motor Co. 1980-89

Front End Shims

FES-248B For use when aligning front ends on most conventional drive cars. 2 of each size: 1/64", 1/32", 1/16", 1/8".

Universal Strapping Kit

GS-110B Universal, 60" plated steel band complete with eye bolts, nuts and washers. Use for miscellaneous repairs.

Grease Fittings, Guns & Supplies

GREASE FITTINGS

SAE for Domestic & Import applications. Zinc plated with built-in spring loaded safety check valve.

GF-1610B 1/8" NPT straight

GF-1611B 1/8" NPT 30° angle

GF-1612B 1/8" NPT 67-1/2° angle

GF-1613B 1/8" NPT 90° angle

GF-1636B 1/4" 28 long thread 45° angle

GF-1637B 1/4" 28 short thread 45° angle

GF-1641B 1/4" 28 thread straight

GF-1688B 1/8" NPT 45° angle

GF-1710B 3/8" 24 thread straight

GF-1711B 5/16" 24 thread straight

GF-1911B 1/4" 28 thread 90° angle

GF-93B 2 each of most popular domestic GF-1610, GF-1613, GF-1637, GF-1641, GF-1911.

GF-100A Contains 20 each: GF-1637, GF-1641, GF-1911; 10 each: GF-1610, GF-1636; 5 each: GF-1611, GF-1613, GF-1688, GF-1710.





Grease Fittings, Guns & Supplies

GREASE FITTINGS Cont'd

- GF-9001B** 6mm straight
- GF-9003B** 8mm straight
- GF-9025B** 10mm straight
- GF-9041B** 6mm 45° angle
- GF-9043B** 8mm 45° angle
- GF-9045B** 10mm 45° angle
- GF-9061B** 6mm 90° angle
- GF-9063B** 8mm 90° angle
- GF-9065B** 10mm 90° angle
- GF-90A** 90 pieces/10 each: 6mm, 8mm, 10mm in straight, 45 and 90° angles.
- GF-92B** 2 each of 6 metric sizes. GF-9001, GF-9003, GF-9025, GF-9041, GF-9043, GF-9061.

GREASE GUNS & CARTRIDGE

- GG-1050N** Heavy-duty, Lever Action Grease Gun includes 1/8" NPT offset pipe, air vent cap and safety lock Up to 10,000 PSI. Uses standard 14.5 oz. grease cartridge. Fills from dispenser or bulk grease pail.
- GG-4120** All-steel, Micro-lube grease gun includes 3-1/2 oz. grease cartridge. Allows easy one-handed operation in tight working areas and on all types of equipment.
- GC-5145B** Contains three 3-1/2 oz. all-purpose lithium grease cartridges for use with hand operated grease gun GG-4120B.

GREASE FITTING COUPLER & OFFSET PIPE

- GF-6304** High-pressure grease fitting coupler features 1/8" female NPT. Fits all standard grease guns, extension pipes and grease whips. 5 per box.
- GF-6304B** 1 per card
- GF-6305B** Standard 1/8" NPT offset grease pipe. Fits all standard grease guns.

GREASE WHIPS

High burst strength, single wire braid, flexible hose. 1/8" NPT ends for use with all grease fitting couplers and hand operated guns. **Not for air powered guns.**

- GW-4598B** 12"
- GW-5066B** 18"

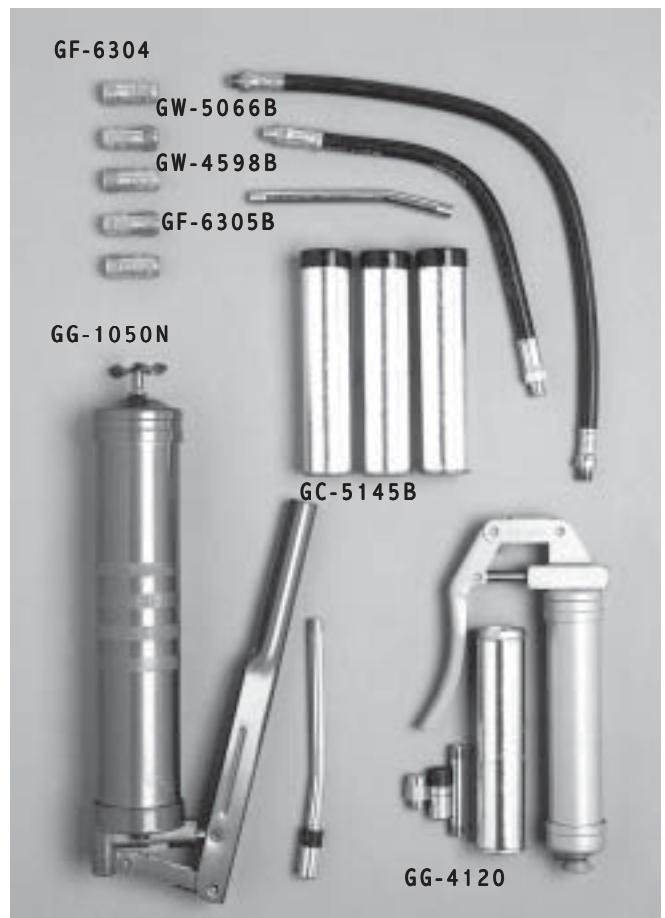

UNDER CAR



CAR
UNDER

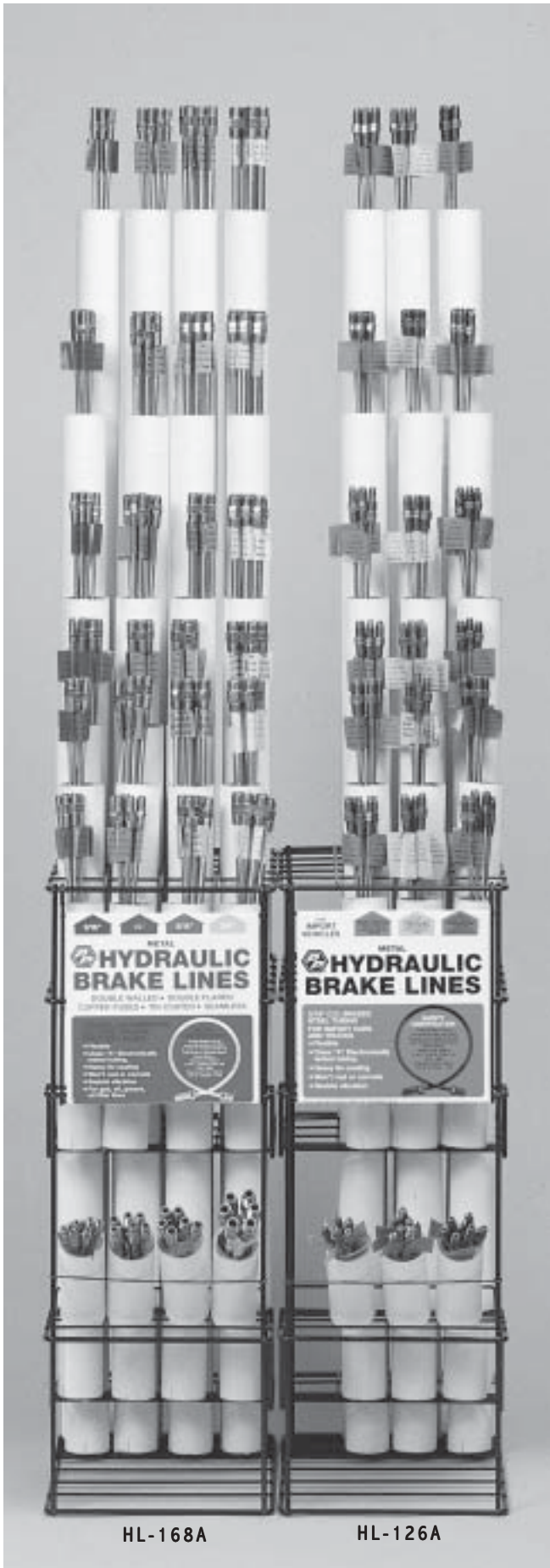

Hydraulic Brake Lines

Flexible brake lines bend easily without kinking. Lines are cut to length with fittings attached ready for immediate installation. Double-flared at both ends to resist vibration. Double-walled, copper fused and tin coated. 4 sizes in a .028 wall "super terne" coated steel tubing, rust and corrosion resistant. Lines longer than 60" are easy to make — union fitting permits instant joining of any combination of lengths.

3/16" & 1/4" O.D.

Double flare with standard inverted SAE flare unit on one end and a long flare nut on opposite end. Fitting on the 3/16" O.D. line has an overall length of .840 and the 1/4" O.D. line has an overall length of .810.

5/16" & 3/8" O.D.

Double flare with standard inverted SAE flare fittings.

FLOOR RACK ASSORTMENTS

Merchandise displays the brake lines in less than 1 square foot! Each line is color coded on the display matching the color keyed labels on each tube.

HL-126A Import Car Hydraulic Line Assortment for European, British and Japanese cars.
6 each of all import lines

HL-168A Domestic Car Hydraulic Line Assortment. US Threads, Standard SAE inverted flare fittings.
6 each of all domestic lines.

DOMESTIC	HYDRAULIC BRAKE LINES	
	Color	Code
HL-308	Red	3/16" x 8"
HL-312	Red	3/16" x 12"
HL-320	Red	3/16" x 20"
HL-330	Red	3/16" x 30"
HL-340	Red	3/16" x 40"
HL-351	Red	3/16" x 51"
HL-360	Red	3/16" x 60"
HL-372	Red	3/16" x 72"
HL-408	Blue	1/4" x 8"
HL-412	Blue	1/4" x 12"
HL-420	Blue	1/4" x 20"
HL-430	Blue	1/4" x 30"
HL-440	Blue	1/4" x 40"
HL-451	Blue	1/4" x 51"
HL-460	Blue	1/4" x 60"
HL-472	Blue	1/4" x 72"
HL-508	Green	5/16" x 8"
HL-512	Green	5/16" x 12"
HL-520	Green	5/16" x 20"
HL-530	Green	5/16" x 30"
HL-540	Green	5/16" x 40"
HL-551	Green	5/16" x 51"
HL-560	Green	5/16" x 60"
HL-572	Green	5/16" x 72"
HL-608	Yellow	3/8" x 8"
HL-612	Yellow	3/8" x 12"
HL-620	Yellow	3/8" x 20"
HL-630	Yellow	3/8" x 30"
HL-640	Yellow	3/8" x 40"
HL-651	Yellow	3/8" x 51"
HL-660	Yellow	3/8" x 60"
HL-672	Yellow	3/8" x 72"

Domestic Brake lines available 6/tube.



Hydraulic Brake Lines Cont'd

IMPORT HYDRAULIC BRAKE LINES

Group 1, Fits Most European Cars (10mm metric thread)

HL-3308	Orange	8"	37° Bubble Flare Inverted nuts
HL-3312	Orange	12"	37° Bubble Flare Inverted nuts
HL-3320	Orange	20"	37° Bubble Flare Inverted nuts
HL-3330	Orange	30"	37° Bubble Flare Inverted nuts
HL-3340	Orange	40"	37° Bubble Flare Inverted nuts
HL-3351	Orange	51"	37° Bubble Flare Inverted nuts
HL-3360	Orange	60"	37° Bubble Flare Inverted nuts

Group 2, Fits most British Cars (10mm metric thread)

HL-3084	Pink	8"	45° SAE Flare Nut	3/16" (4.72mm) OD	Metric thread	Standard Flare
HL-3124	Pink	12"	45° SAE Flare Nut	3/16" (4.72mm) OD	Metric thread	Standard Flare
HL-3204	Pink	20"	45° SAE Flare Nut	3/16" (4.72mm) OD	Metric thread	Standard Flare
HL-3304	Pink	30"	45° SAE Flare Nut	3/16" (4.72mm) OD	Metric thread	Standard Flare
HL-3404	Pink	40"	45° SAE Flare Nut	3/16" (4.72mm) OD	Metric thread	Standard Flare
HL-3514	Pink	51"	45° SAE Flare Nut	3/16" (4.72mm) OD	Metric thread	Standard Flare
HL-3604	Pink	60"	45° SAE Flare Nut	3/16" (4.72mm) OD	Metric thread	Standard Flare

Group 3

HL-3080	Tan	8"	45° Bubble Flare Nut	US thread	Fits most Japanese Cars
HL-3120	Tan	12"	45° Bubble Flare Nut	US thread	Fits most Japanese Cars
HL-3200	Tan	20"	45° Bubble Flare Nut	US thread	Fits most Japanese Cars
HL-3300	Tan	30"	45° Bubble Flare Nut	US thread	Fits most Japanese Cars
HL-3400	Tan	40"	45° Bubble Flare Nut	US thread	Fits most Japanese Cars
HL-3510	Tan	51"	45° Bubble Flare Nut	US thread	Fits most Japanese Cars
HL-3600	Tan	60"	45° Bubble Flare Nut	US thread	Fits most Japanese Cars

Import Brake lines available 6/tube.

Hydraulic Brake Line Unions

- HLU-300B** 3/16" inverted flare
Use with HL-300 series.
- HLU-400B** 1/4" inverted flare
Use with HL-400 series.
- HLU-500B** 5/16" inverted flare
Use with HL-500 series.
- HLU-600B** 3/8" inverted flare
Use with HL-600 series.
- HLU-700B** 3/16" inverted flare, with Female M10-1.0mm thread. Fits most Japanese cars.
- HLU-800B** 3/16" female bubble flare, with 3/8"x24 Thread. Use with Group 3 lines.
- HLU-900B** 3/16" female bubble flare, with M10 mm Thread British. Use with Group 1 lines.

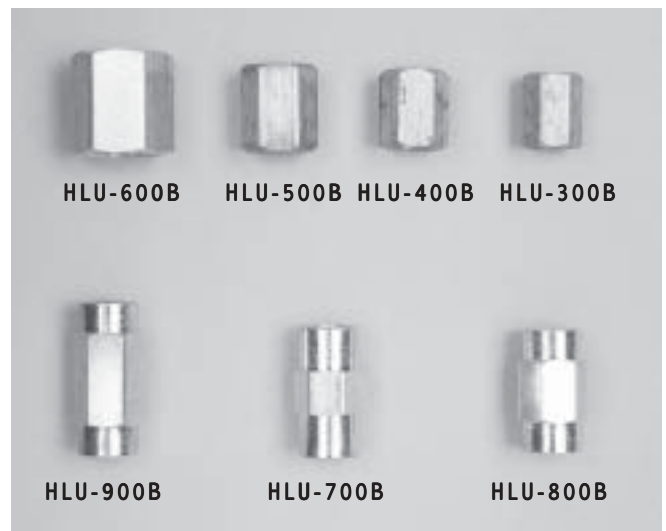

UNDER CAR



CAR
UNDER

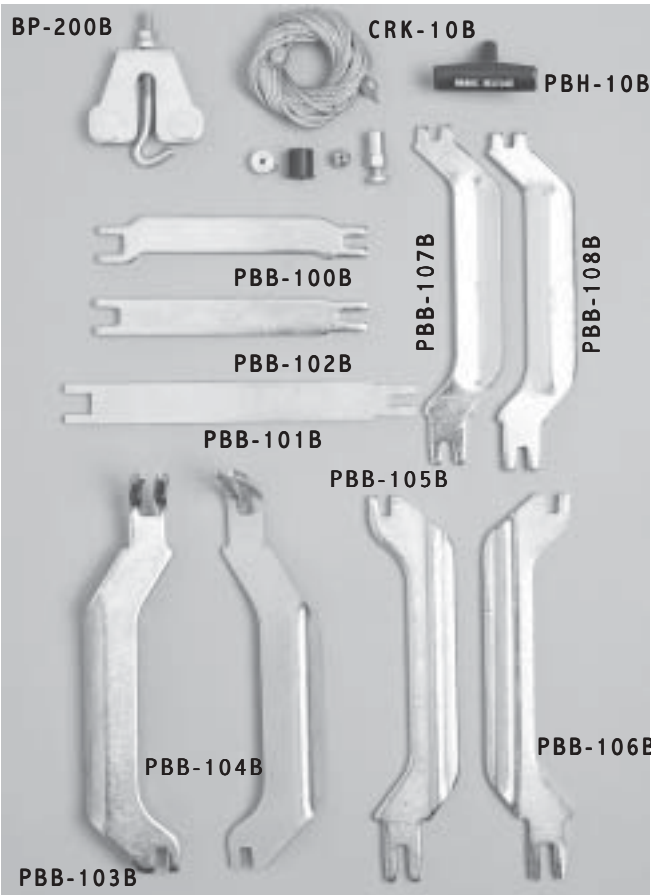

For Brake Service parts see pages 82-84 in *Under Car*

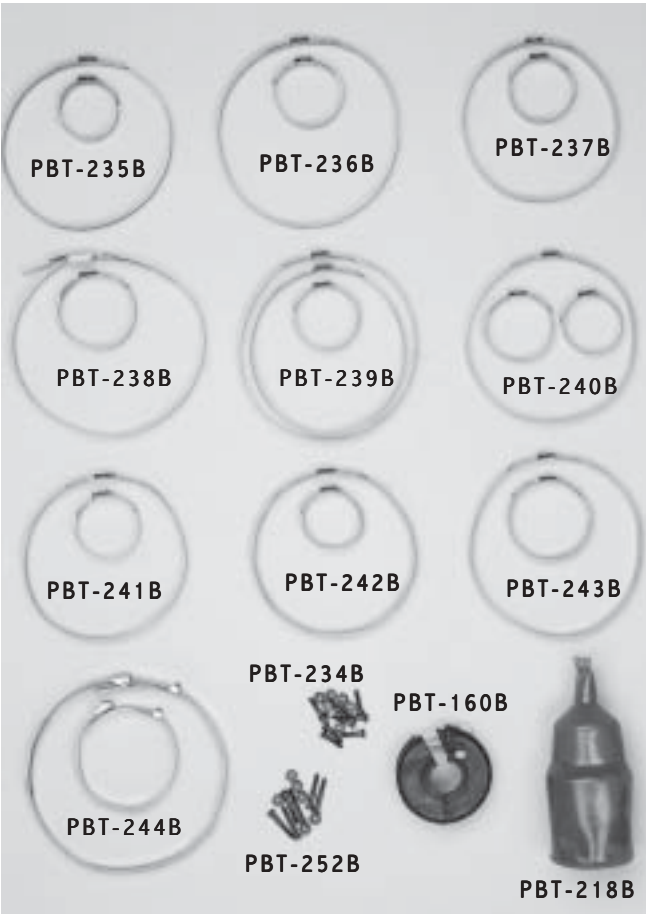

Parking Brake Repair

PARKING BRAKE BARS (DRUM)

- PBB-100B** Right and left sides. GM 1964-up
- PBB-101B** Left side. GM with 11" brakes
- PBB-102B** Right and left sides. Ford Motor Co. with 9" brakes
- PBB-103B** Right side. Chrysler Corp. Rear wheel drive models 1977-up
- PBB-104B** Left side. Chrysler Corp. Rear wheel drive models 1977-up
- PBB-105B** Left side. Ford Motor Co. Full size 1976-up; Intermediate models 1979-74
- PBB-106B** Right side. Ford Motor Co. Full size 1976-up; Intermediate models 1979-74
- PBB-107B** Right side. Ford Motor Co. 1989-74 with 10" brakes
- PBB-108B** Left side. Ford 1989-74 with 10" brakes

PARKING BRAKE CABLE REPAIR KIT

CRK-10B Easy installation. Eliminates the need to replace the entire cable.

PARKING BRAKE CABLE SHORTENER

BP-200B Zinc plated steel body and hook with 2 locking nuts. For use on all cars and trucks to prolong cable life for safety.

PARKING BRAKE HANDLE

PBH-10B For underdash applications. Features screw on handle. GM 1973-up.

Perfect Boot™

BOOT CLAMP SETS

- PBT-235B** GM A, J, X cars
- PBT-236B** GM E, K cars
- PBT-237B** Chrysler w/Citroen driveshaft, Honda
- PBT-238B** Cadillac Eldorado, Oldsmobile Toronado
- PBT-239B** AMC/Eagle, Audi/Volkswagen (Tubular), Isuzu, LUV, Subaru
- PBT-240B** Nissan Sentra, Toyota Tercel
- PBT-241B** Chrysler w/GKN driveshaft
- PBT-242B** Audi/Volkswagen w/solid axle Chrysler w/ACI driveshaft, Ford, Mazda GLC, Nissan F10, 310, Subaru 1980-86 2WD
- PBT-243B** Renault Alliance, Encore
- PBT-244B** Universal Clamp Kit

CV JOINT BOOT PREP KITS

- PBT-234B** Contains 6 short screws and nuts
- PBT-252B** Contains 6 long screws and nuts

CV JOINT GREASE

PBT-218B 3 oz. tube, one boot supply

TIE-ROD SPLIT BOOT

PBT-160B Universal



Perfect Boot™ Cont'd

OUTER BOOT KITS

- PBT-100B** Audi/Volkswagen w/solid axle
- PBT-101B** GM E and K cars
- PBT-102B** GM A, J, and X cars
- PBT-103B** Ford, Mercury
- PBT-104B** Chrysler w/Citroen driveshaft
- PBT-105B** Chrysler w/GKN driveshaft
- PBT-106B** Honda
- PBT-107B** Subaru
- PBT-108B** American Motors
- PBT-109B** Cadillac Eldorado, Oldsmobile Toronado 1967-78
- PBT-110B** Chrysler, Ford w/ACI driveshaft
- PBT-111B** Mazda, Nissan, Subaru
- PBT-112B** Nissan Sentra
- PBT-113B** Toyota Tercel
- PBT-114B** Renault Alliance, Encore
- PBT-115B** Audi/Volkswagen w/Tubular axle
- PBT-161B** GM w/.945" dia driveshaft
- PBT-162B** GM w/1.075" dia. driveshaft
- PBT-263B** Split Boot - Mazda
- PBT-270B** Steering Boot - Universal
- PBT-280B** Solid Boot - Universal

Power Train

U-JOINT RETAINER KITS

Replace lost or damaged joint retainers.

- UJB-1B** Strap-type. GM Vehicles 1967-up
- UJB-2B** U-bolt type. GM Vehicles 1968-80
- UJB-3B** U-bolt type. Ford with 1/8" OD bearing
- UJB-4B** Strap-type. Chrysler Corp. with 1-5/64" OD bearing
- UJB-5B** U-bolt type. Jeep 1962-79



UNDER

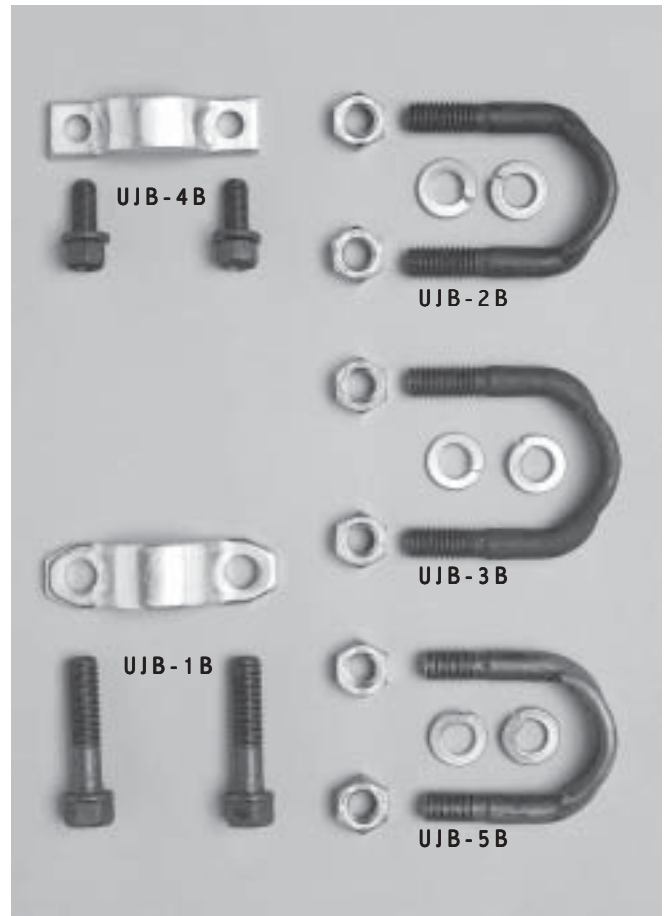

CAR



CAR
UNDER

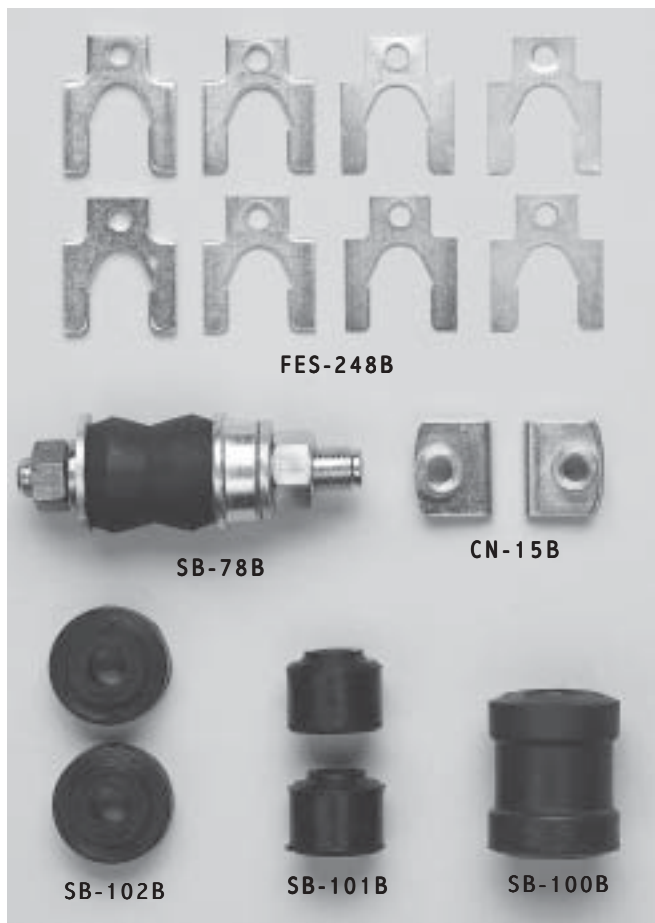

Suspension System Parts

SHIMS — FRONT END

FES-248B For use when aligning front ends on most conventional drive cars. 2 of each size: 1/64", 1/32", 1/16", 1/8".

SHOCK BOLT — UNIVERSAL

SB-78B Use with most shock absorbers when original bolt is lost or damaged. All necessary hardware included.

SHOCK BUSHINGS

Replaces worn shock absorber bushings.

SB-100B Large size. Chrysler Corp. and GM

SB-101B Small size. Chrysler Corp. and GM, also fits 80% over sway bar link applications.

SB-102B Replaces worn or decaying shock absorber bushings. Fits Ford Motor Co. and some sway bar link applications.

SB-103B Small size. Ford and Mercury. Resilient rubber compound construction.

SHOCK CLIP NUTS

CN-15B Heavy duty zinc plated. Use when weld breaks on lower shock cross bar nut. Fits most domestic cars.

CN-15C Display card contains 20 CN-15.

CN-20B "A" Frame Clip Nuts. 8mm x 1.0 thread size. Attaches front shocks to lower control arm. Plated for corrosion resistance. 2 per card.



SPINDLE LOCK NUTS & KITS

Kits are manufactured to OEM specifications, includes all necessary hardware. Use one kit for one wheel to make accurate wheel bearing adjustment.

SN-1B Chrysler, Dodge 1928-90; DeSoto 1928-61
Ford 1928-54; Lincoln, Mercury 1949-54; Plymouth 1955-82

SN-5B AMC 1955-76. Ford (Exc. station wagon), Lincoln, Mercury 1955-72; Plymouth 1928-54; Studebaker 1936-64.

SN-10B Comet (6 cyl.) 1960-69; Cougar 1967-72; Falcon 1960-69; Maverick 1970-72; Mustang 1965-72.

SN-15B Buick standard 1972-90, Special 1964-72; Cadillac (Exc. Cimmaron, Eldorado) 1973-89; Chevrolet std. 1946-90; Chevelle, Nova 1965-83; Oldsmobile standard 1964-90; Toronado 1976-81; Oldsmobile (Exc. F-85, Delta 88) 1939-77; Bonneville, Firebird 1982-87; Pontiac (Exc. Astre, Sunbird) 1933-81.

SN-20B Ford Motor Co. incl. compacts 1973-79

SN-25B Dodge Omni, Plymouth Horizon 1978

SN-30B Aries, Horizon, Omni and Reliant 1979-88
Replaces Chrysler 5212525, 6500298, 6500299.

SN-31B Honda Rear, Accord, Prelude 1977-83; Civic 1980-83 (Not Shown)

SN-32B Volkswagen FWD 1974-89, Rear

SN-35B Nissan RWD all models Front 1971-90

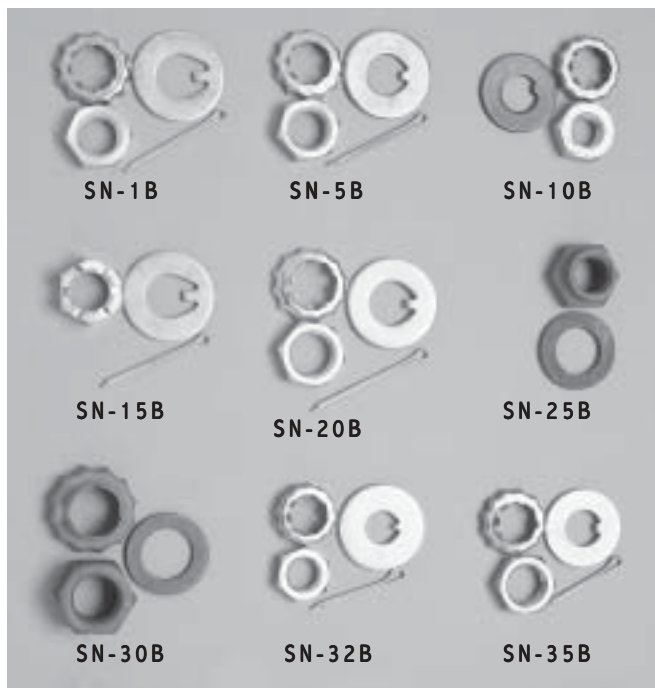



Suspension System Parts Cont'd

SPINDLE LOCK NUTS & KITS Cont'd

- SN-36B** Honda Front, Accord 1976-83;
Civic 1980-83; Prelude 1979-83
- SN-37B** GM Vehicles FWD 1980-90
- SN-38B** GM Vehicles FWD 1983-90
- SN-39B** AMC and Ford Motor Co. RWD 1970-90
(Not Shown)
- SN-40B** Ford Motor Co. FWD 1984-90
- SN-41B** 19mm x 1.5, 30mm hex, 11.1mm high.
Front: Chevrolet Nova; Geo Prizm; Toyota Camry, Celica, Corolla, Previa, Tercel.
- SN-42B** 22mm x 1.5, 30mm hex, 14.0mm high.
Front: Geo Prizm; Toyota Camry, Celica, Corolla, Paseo, Previa, Tercel.
- SN-43B** 27mm x 2.0, 34mm hex, 17.7mm high.
Front: Fullsize Buick, Cadillac, Oldsmobile Pontiac; Lumina APV, Silhouette APV, Trans Sport APV; Chrysler Concorde, Dodge Intrepid, Eagle Vision.
- SN-44B** 1 1/16" x 24, 1" hex, .50" high.
Front: GM Astre, Monza, Skyhawk, Starfire, Sunbird, Vega.
- SN-45B** 3/4" x 20, 1-1/16" hex, .28" high.
Front: Chevrolet Camaro, Pontiac Firebird 1991-92.
- SN-46B** 27/32" x 20, 1-1/4" hex, .55" high.
Front: Chevrolet Corvette, GMC Fullsize 2WD Pick-Up, Blazer, Jimmy, Yukon, Van, Suburban.
- SN-47B** 24mm x 2.0, 36mm hex, 20.9mm high.
Rear: Ford T-Bird, Lincoln Mark VIII, Mercury Cougar.
- SN-49B** 24mm x 2.0, 36mm hex, 21.3mm high.
Front: Fullsize Ford Mustang, T-Bird, Lincoln Mark VIII, Mercury Cougar.
- SN-50B** 24mm x 2.0, 36mm hex, 20.4mm high.
Rear: Ford Taurus, Lincoln Continental, Mercury Sable 1990-94.
- SN-51B** 22mm x 1.5, 32mm hex, 20.2mm high.
Front: Eagle Summit, Talon; Hyundai Elantra, Excel, Scoupe, Sonata; Mitsubishi 3000 GT, Cordia, Diamante, Eclipse, Expo, Galant, Mirage, Precis, Tredia; Plymouth Laser.
- SN-52B** 20mm x 1.5, 30mm hex, 16.2mm high.
Front: Eagle Medallion, Premier; Dodge Monaco; Renault 18i, Alliance, Encore, Fuego; Saab 900.
- SN-53B** 22mm x 1.5, 32mm hex, 13.1mm high.
Front: Honda Accord, Civic.
- SN-54B** 24mm x 1.5, 36mm hex, 23.1mm high.
Front: Acura Legend, Vigor; Honda Accord, Prelude. Rear: Honda Prelude 1988-91.

Suspension System Parts Cont'd

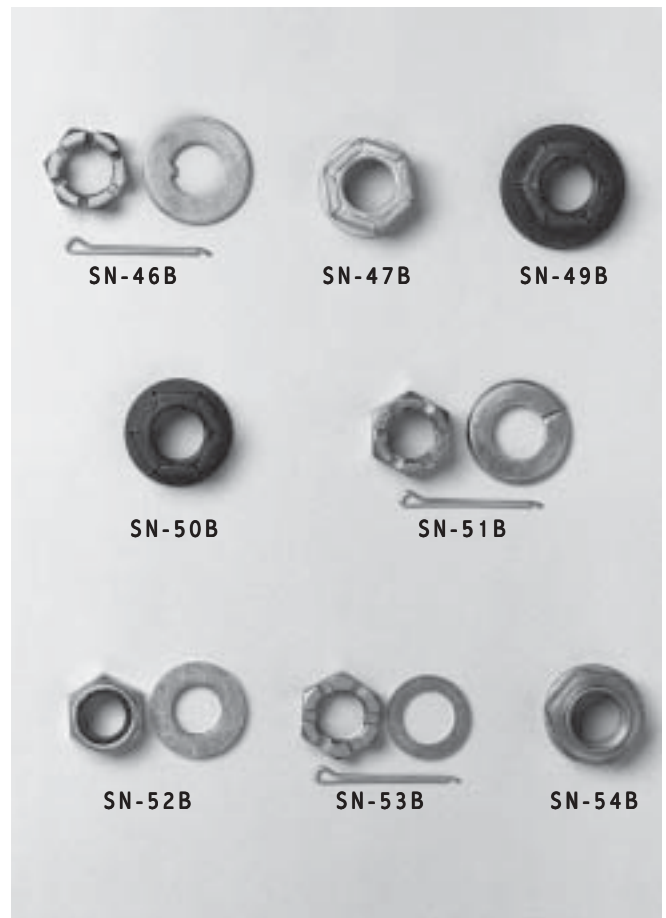
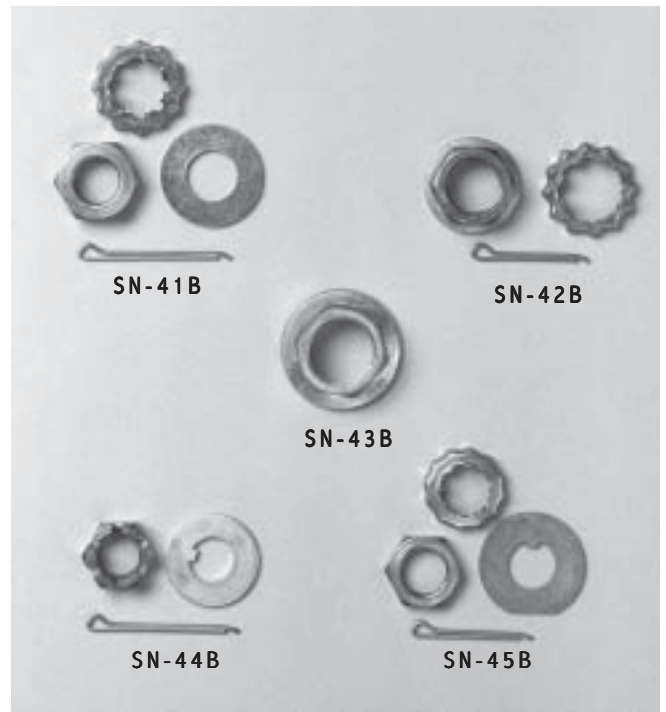

UNDER CAR



CAR
UNDER

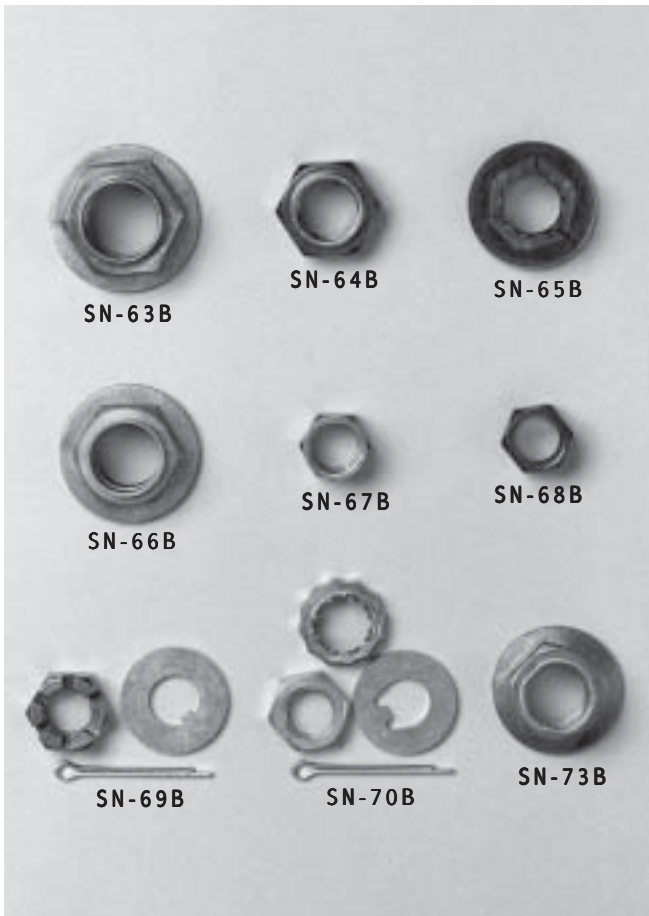

SPINDLE LOCK NUTS & KITS Cont'd

- SN-55B** 22mm x 1.0, 32mm hex, 20.6mm high.
Rear: Mazda RX7 1989-92. Front & Rear: Mazda 929 1988-91.
- SN-56B** 22mm x 1.0, 32mm hex, 17.9mm high.
Front: Nissan 310, 310GX, Pulsar, Sentra, Stanza.
- SN-57B** 24mm x 1.5, 36mm hex, 18.9mm high.
Front: Nissan Altima, Axxess, Maxima, Stanza.
Rear: Nissan 240SX, Axxess, Sentra, 4WD.
- SN-58B** 19mm x 1.5, 30mm hex, 11.0mm high.
Front: Toyota 4Runner, Celica, Corona, Cressida, Pick-Up, Tercel, Van.
- SN-59B** 20mm x 1.0, 30mm hex, 25.0mm high.
Front: Chevrolet Spectrum; Geo Storm; Isuzu I-Mark, Impulse, Stylus. Rear: Geo Storm; Isuzu Impulse.
- SN-60B** 22mm x 1.5, 32mm hex, 21.1mm high.
Front & Rear: Subaru Impreza, Legacy, SVX.
- SN-61B** 20mm x 1.5, 30mm hex, 13.5mm high.
Front: Audi 4000, Coupe, Fox, Quattro 4000; VW Cabriolet, Corrado, Dasher, Fox, Golf, GTI, Jetta, Passat, Quantum, Rabbit, Scirocco.
- SN-62B** 3/4" x 16, 1-1/8" hex, .65" high.
Front: Ford Truck E100-300, F100-350, P350-400.
- SN-63B** 24mm x 1.5, 35mm hex, 24.4mm high.
Front: Mazda MPV. Front & Rear: Mazda 929, RX7.
- SN-64B** 20mm x 1.5, 30mm hex, 17.5mm high.
Front: Ford Festiva, Mercury Capri, Tracer; Mazda 323, 626, GLC.
- SN-65B** 20mm x 1.5, 30mm hex, 18.3mm high.
Front: Ford Escort, EXP, Tempo, Mercury Lynx, LN7, Topaz
- SN-66B** 22mm x 1.5, 32mm hex, 20.6mm high.
Front & Rear: Ford Escort, Probe, Mercury Tracer; Mazda 323, MX3, MX6, Protege.
- SN-67B** 16mm x 1.5, 21mm hex, 15.2mm high.
Left hand, Rear: Ford Festiva, Mercury Capri, Tracer; Mazda 323.
- SN-68B** 16mm x 1.5, 21mm hex, 15.2mm high.
Right hand, Rear: Ford Festiva, Mercury Capri, Tracer; Mazda 323.
- SN-69B** 16mm x 1.0, 24mm hex, 12.0mm high.
Front: Chevrolet Chevette, Pontiac Fiero, T1000.
- SN-70B** 16mm x 1.0, 24mm hex, 7.8mm high.
Rear: Audi 4000, 4000S Coupe; VW Cabriolet, Corrado, Dasher, Fox, Golf, GTI, Jetta, Passat, Quantum, Rabbit, Scirocco.
- SN-73B** 20mm x 1.5, 30mm hex, 20.8mm high.
Rear: Hyundai Elantra, Excel, Scoupe; Mitsubishi Precis.



Suspension System Parts Cont'd

SPRING CENTER BOLTS

Hardened steel center bolts with nut, for most leaf springs on cars and trucks. All have extra long threads which can be cut to size if needed.

	Size	x Thread	x Length	Qty
SCB-10B	5/16"	24	3-1/2"	12/bx
SCB-110B				1/cd
SCB-11B	3/8"	24	3-1/2"	12/bx
SCB-111B				1/cd
SCB-12B	5/16"	24	5"	12/bx
SCB-112B				1/cd
SCB-13B	3/8"	24	5"	12/bx
SCB-113B				1/cd
SCB-17B	5/16"	24	6"	12/bx
SCB-117B				1/cd
SCB-18B	3/8"	24	8"	12/bx
SCB-118B				1/cd
SCB-19B	7/16"	20	8"	12/bx
SCB-119B				1/cd
SCB-21B	1/2"	20	10"	12/bx
SCB-121B				1/cd
SCB-32B	7/16"	20	12"	12/bx
SCB-132B				1/cd
SCB-40B	3/8"	24	6"	12/bx
SCB-140B				1/cd
SCB-45B	3/8"	24	12"	12/bx
SCB-145B				1/cd

SPRING STABILIZERS

Restore original height to coil springs, front and rear. Stabilizers reduce front end dive when brakes are applied, correct sway and tire squeal on turns. Use 2 stabilizers per spring. No special tools needed. 2/card.

- SA-1B** For front springs. Firm, durable rubber.
- SA-2B** For rear springs. Large size, rubber.
- SA-5B** For front springs. Cast aluminum with two heights. Just snap in.
- SA-6B** For front springs. Cast aluminum screw-in type.
- SA-7B** For front springs. Adjustable stabilizers raise height from 15/16" to 1-1/2"
- SA-9B** For rear springs. Large size, cast aluminum screw-in type.

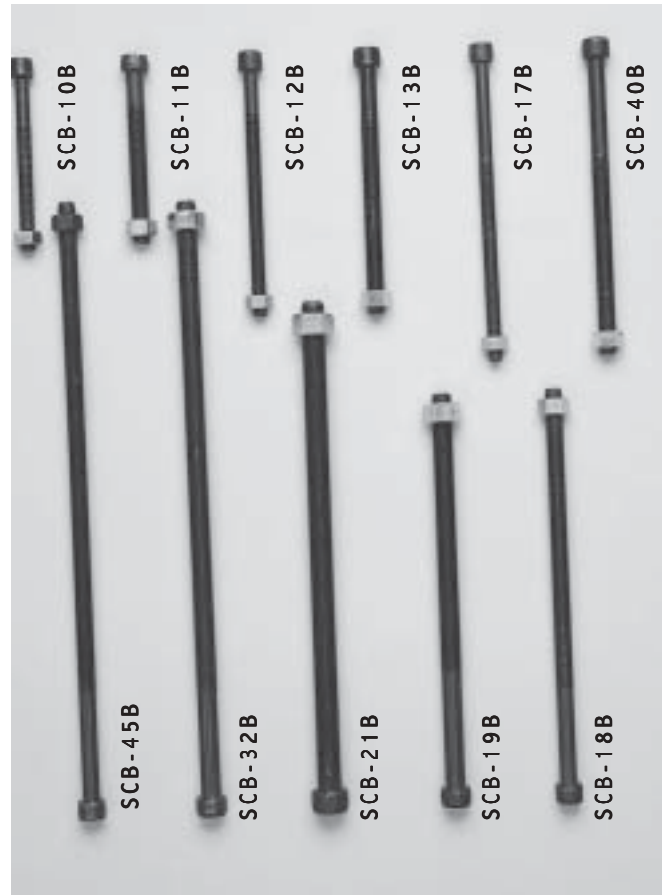

UNDER

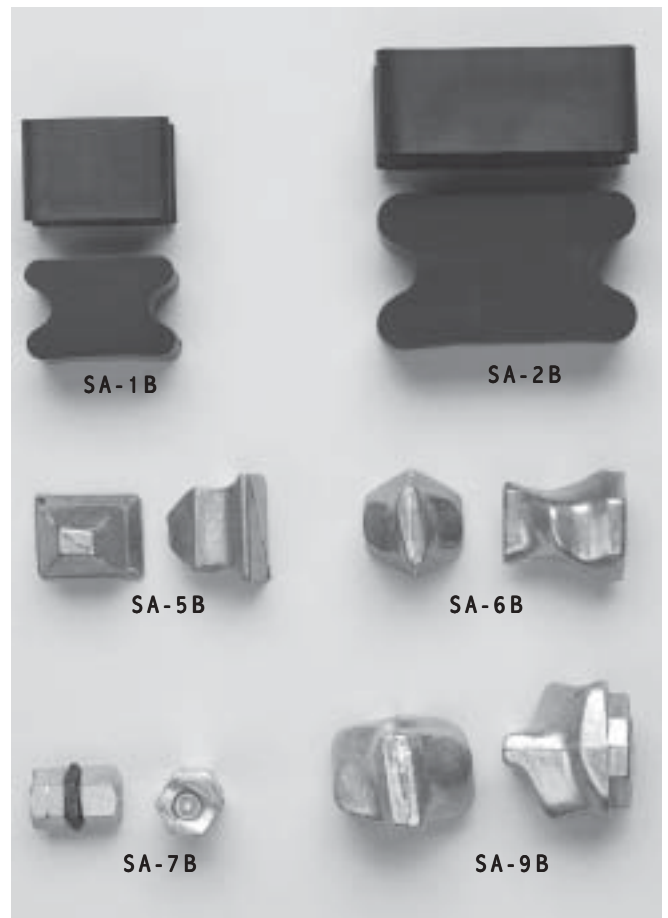

CAR

SUSPENSION

SYSTEM

PARTS

— SPRING

U-BOLTS



Suspension System Parts Cont'd

SPRING U-BOLTS

1 bolt, 2 nuts per card

For mounting leaf springs on cars, trucks, RV's , marine trailers. Match old part with new to ensure proper fit.

	Type	Dia.	Width	Length
UB-1B	Round	7/16"	2-1/2"	6-1/2"
UB-2B	Round	7/16"	2-7/8"	8-3/8"
UB-3B	Round	7/16"	3-1/2"	6-3/4"
UB-4B	Round	1/2"	2-7/8"	7"
UB-5B	Round	1/2"	3"	8-1/4"
UB-6B	Round	1/2"	3-1/8"	6-1/2"
UB-7B	Round	1/2"	3-1/8"	7-1/2"
UB-8B	Round	1/2"	3-3/16"	8"
UB-9B	Round	1/2"	3-1/8"	9"
UB-10B	Round	9/16"	3"	7-3/4"
UB-11B	Round	9/16"	3-3/8"	10-5/8"
UB-12B	Round	5/8"	3-1/8"	8-1/4"
UB-13B	Round	5/8"	3-1/4"	8-3/4"

CAR

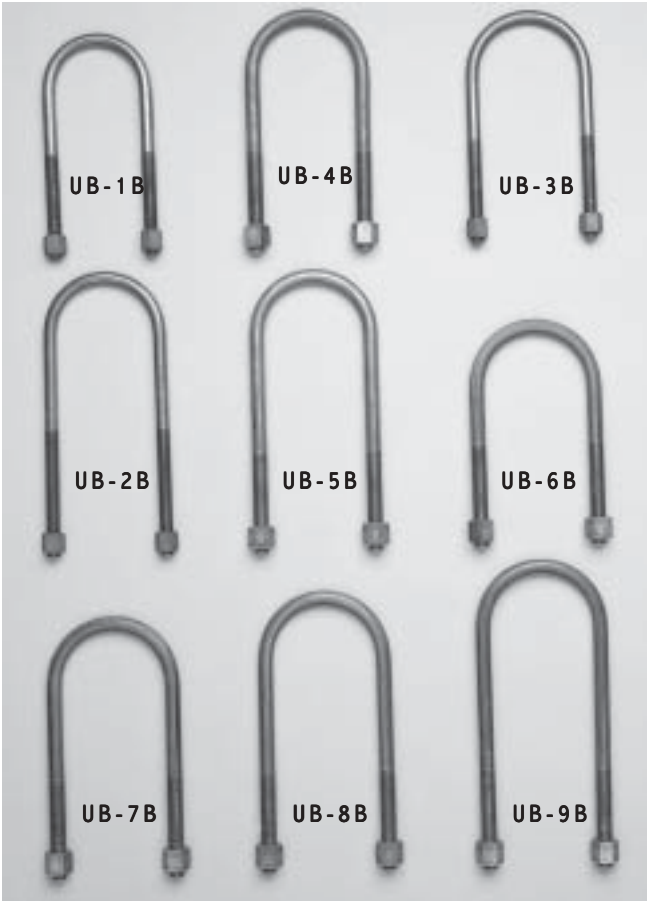

UNDER

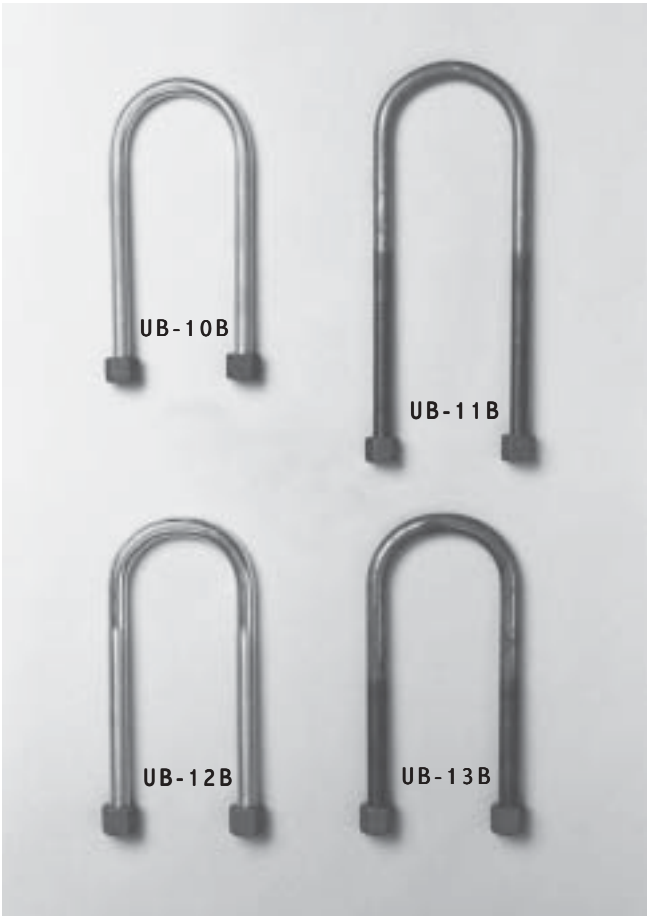



Suspension System Parts Cont'd

STRUT MOUNTS & BEARINGS

To prevent strut problems, it's recommended that the strut mount be replaced each time a new MacPherson Strut is installed. Also if steel housing is damaged, rubber bushing is worn or cracked, or if bearing is faulty. All mounts are OEM replacement.

STRUT MOUNTS

- SM-100B** Front Chrysler Corp. 1979-up, includes Spacer, Bearing and Retainer
- SM-101B** Rear Rear strut upper spring seat Omni, Horizon 1978-up
- SM-102B** Front Ford, Mercury 1981-85, includes Mount, Bearing and Retainer
- SM-103B** Front Chrysler Corp. 1984-86, includes Mount, Bearing and Retainer
- SM-104B** Front Chrysler Corp. 1986-up, includes Mount, Bearing and Retainer
- SM-106B** Front Chrysler Corp. 1983 includes Mount and Bearing
- SM-107B** Front Volkswagen 1975-87, includes Mount and Bearing
- SM-108B** Front Volkswagen 1985-90
- SM-109B** Rear GM Vehicles (FWD) 1984-up

STRUT BEARINGS

- SM-105B** Chrysler Corp. (FWD) 1986-up (Exc. Horizon, Omni, and 1990 Laser)
- SM-110B** Ford Motor Co. 1986-up
- SM-111B** Ford, Mercury 1985-up

TIE ROD DUST BOOTS

Replaces worn and damaged tie rod boots without replacing entire unit. Prevents water and dirt from destroying the tie rod.

- TRB-10B** Fits all steering tie rods with 1/2" diameter shafts.
- TRB-11B** Fits all steering tie rods with 9/16" diameter shafts. Not shown. Same as TRB-10, only 9/16" shaft.
- TRB-12B** Fits all steering tie rods with 5/8" diameter shafts.
- TRB-13B** Fits all steering tie rods with 3/4" diameter shafts. Replaces worn and damaged tie rod boots without replacing entire unit. Prevents water and dirt from destroying the ball joint or tie rod end. *Not shown.*

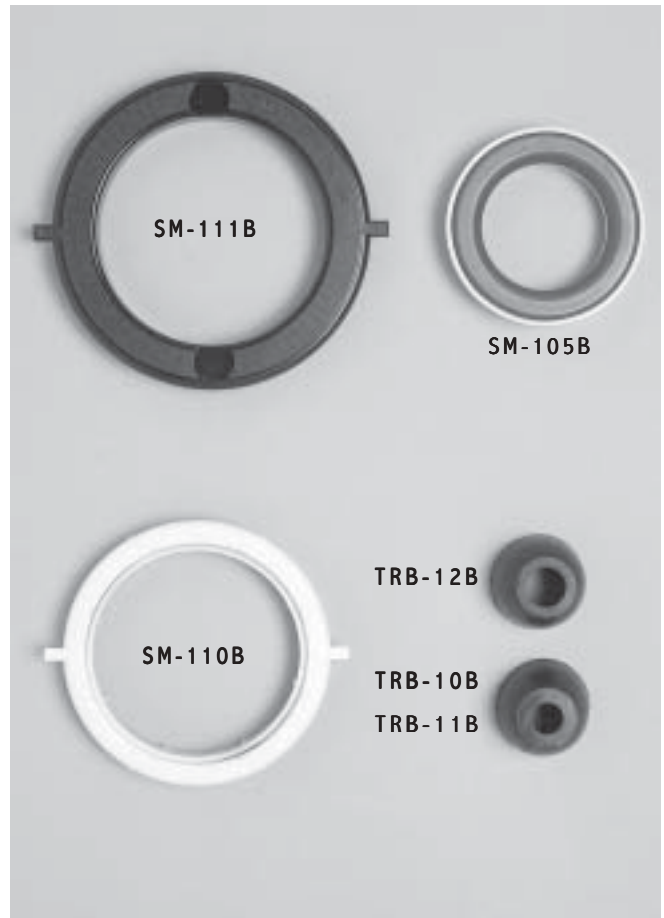
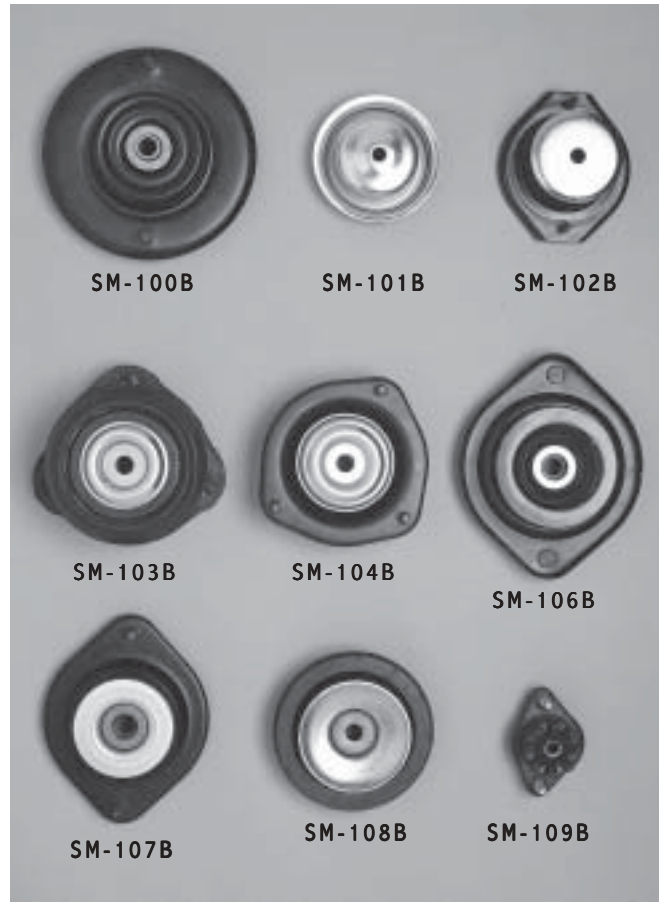

UNDER CAR



Wheel Dust Caps

Prevents mud, dust and dirt from reaching bearings. For domestic and import applications

GC-232B Fits 1-9/16" (39.68 mm) I.D. hub. on GM, Chrysler, Ford, Toyota and Volkswagen.

GC-233B Fits 1-25/32" (45.25 mm) I.D. hub on AMC, Chrysler, Ford, GM, Honda and Nissan

GC-234B Fits 2-3/32" (53.19 mm) I.D. hub on GM.

GC-235B Fits 1-31/32" (49.98 mm) diameter hubs on Ford trucks and vans with light-duty brakes.

GC-236B Fits 2-1/2" (63.5 mm) diameter hubs on Ford trucks and vans with heavy-duty brakes.

GC-237B Fits 2" (50.8mm) diameter hubs on Honda.

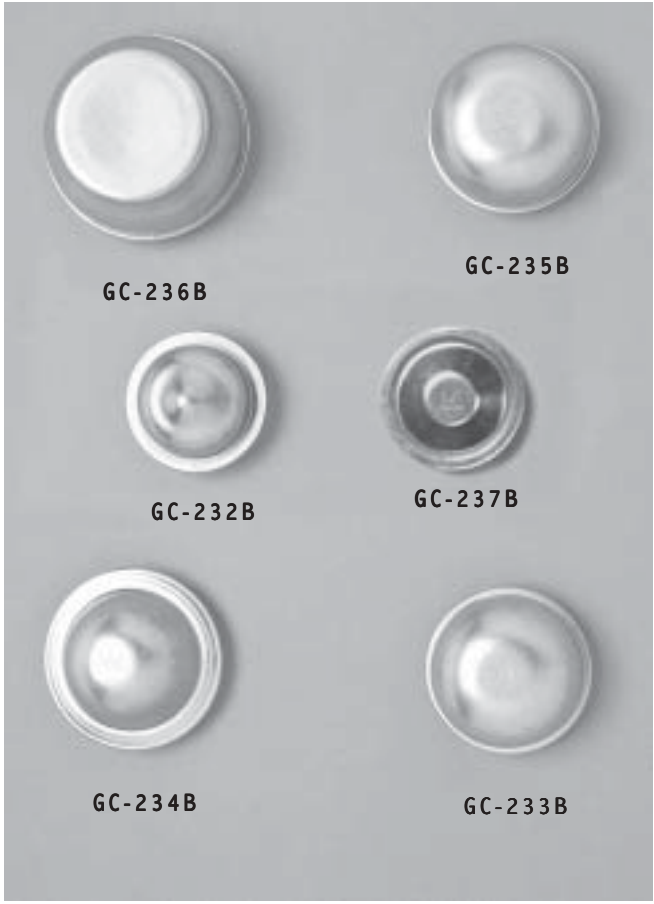

CAR UNDER